

Ruijie Reeye RG-ES110GS-P-L Switch

Installation Guide

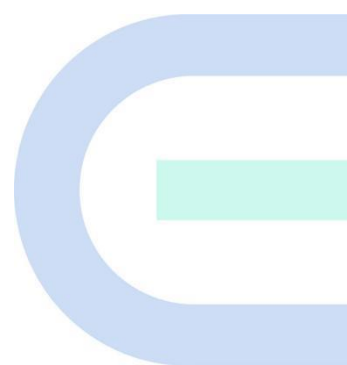

Copyright

Copyright © 2026 Ruijie Networks

All rights are reserved in this document and this statement.

Without the prior written consent of Ruijie Networks, no organization or individual is permitted to reproduce, extract, back up, modify, or distribute the content of this document in any manner or form. It is also prohibited to translate the document into other languages or use any or all parts of it for commercial purposes.



and other Ruijie networks logos are trademarks of Ruijie Networks.

All other trademarks or registered trademarks mentioned in this document are owned by their respective owners.

Disclaimer

The products, services, or features you purchase are subject to commercial contracts and terms, and some or all of the products, services, or features described in this document may not be available for you to purchase or use. Except for the agreement in the contract, Ruijie Networks makes no explicit or implicit statements or warranties with respect to the content of this document.

The names, links, descriptions, screenshots, and any other information regarding third-party software mentioned in this document are provided for your reference only. Ruijie Networks does not explicitly or implicitly endorse or recommend the use of any third-party software and does not make any assurances or guarantees concerning the applicability, security, or legality of such software. You should choose and use third-party software based on your business requirements and obtain proper authorization. Ruijie Networks assumes no liability for any risks or damages arising from your use of third-party software.

The content of this document will be updated from time to time due to product version upgrades or other reasons, Ruijie Networks reserves the right to modify the content of the document without any notice or prompt.

This manual is designed merely as a user guide. Ruijie Networks has tried its best to ensure the accuracy and reliability of the content when compiling this manual, but it does not guarantee that the content of the manual is completely free of errors or omissions, and all the information in this manual does not constitute any explicit or implicit warranties.

Preface

Intended Audience

This document is intended for:

- Network engineers
- Technical support and servicing engineers
- Network administrators

Technical Support

- Ruijie Reye website: <https://reyee.ruijie.com>
- Online support center: <https://reyee.ruijie.com/en-global/support>
- Case portal: <https://www.ruijie.com/support/caseportal>
- Community: <https://community.ruijie.com>
- Email support: service_rj@ruijie.com
- Live chat: <https://reyee.ruijie.com/en-global/rita>

Conventions

1. Signs

The signs used in this document are described as below:

 **Danger**
An alert that calls attention to safety operation instructions that if not understood or followed when operating the device can result in physical injury.

 **Warning**
An alert that calls attention to important rules and information that if not understood or followed can result in data loss or equipment damage.

 **Caution**
An alert that calls attention to essential information that if not understood or followed can result in function failure or performance degradation.

 **Note**
An alert that contains additional or supplementary information that if not understood or followed will not lead to serious consequences.

 **Specification**
An alert that contains a description of product or version support.

2. Note

This manual provides the device installation steps, hardware troubleshooting, module technical specifications, and specifications and usage guidelines for cables and connectors. It is intended for the users who have some experience in installing and maintaining network hardware. At the same time, it is assumed that the users are already familiar with the related terms and concepts.

Contents

Preface	I
1 Product Overview	1
1.1 Package Contents.....	1
1.2 Appearance.....	1
1.2.1 Front Panel.....	2
1.2.2 Rear Panel	4
1.3 Technical Specifications	4
1.4 Cooling.....	7
2 Preparing for Installation	8
2.1 Safety Precautions.....	8
2.1.1 General Safety Precautions.....	8
2.1.2 Handling Safety.....	8
2.1.3 Electrical Safety	8
2.1.4 ESD Safety.....	9
2.1.5 Laser Safety	9
2.2 Installation Environment Requirements.....	10
2.2.1 Bearing Requirements	10
2.2.2 Ventilation Requirements.....	10
2.2.3 Space Requirements	10
2.2.4 Temperature and Humidity Requirements	10
2.2.5 Cleanliness Requirements.....	10
2.2.6 Grounding Requirements.....	11
2.2.7 Anti-interference Requirements	12

2.2.8 Lightning Protection Requirements	12
2.2.9 Installation Site Requirements	12
2.3 Tools	13
3 Installing the Switch	14
3.1 Before You Begin.....	14
3.2 Precautions	14
3.3 Mounting the Switch	14
3.3.1 Mounting the Switch on a Wall	14
3.3.2 Mounting the Switch on a Workbench	15
3.4 Grounding the Switch	16
3.4.1 Connecting the Power Cord.....	16
3.5 Checking after Installation	16
4 Debugging	17
4.1 Powering on the Switch	17
4.1.1 Checklist Before Power-On	17
4.1.2 Checklist After Power-on	17
4.2 Adding Unmanaged Device to Topology.....	17
4.2.1 Scanning QR-code of Unmanaged Device	17
4.2.2 Adding Unmanaged Device Manually.....	18
5 Appendix.....	20
5.1 Connectors and Media.....	20
5.2 Mini-GBIC and SFP Modules.....	21
5.3 Lightning Protection	24
5.3.1 Installing the AC Power Arrester	24

5.3.2 Installing the Ethernet Port Arrester.....25

1 Product Overview

The RG-ES110GS-P-L switch is a 1000 Mbps Ethernet PoE switch featuring nine 10/100/1000Base-T ports with auto-negotiation and one 1000 Mbps SFP port with line-rate forwarding performance. As the eight ports are PoE-capable and are backward compatible with the IEEE802.3at standard, the RG-ES110GS-P-L switch can automatically detect and supply power to devices compliant with IEEE802.3at/af standards through Ethernet cables. Additionally, you can adjust the switch's working mode by toggling the DIP switch on the front panel for extend mode and port isolation.

The RG-ES110GS-P-L switch offers easy operation and supports plug-and-play, requiring no additional configuration. It can work with a wide range of video monitoring devices and access points, providing flexibility without being limited by electrical wiring constraints. This switch is an ideal choice for small- and medium-sized Ethernet networks.

1.1 Package Contents

Table 1-1 Package Contents

Item	Quantity
RG-ES110GS-P-L Switch	1
Power Cord	1
Warranty Card	1
User Manual	1

Note

The package contents are subject to the purchase contract, and actual delivery may vary. Please check the items carefully against the package contents or purchase contract. If you have any questions or notice any errors, please contact your distributor.

1.2 Appearance

The RG-ES110GS-P-L switch provides nine 10/100/1000Base-T ports with auto-negotiation and one 1000 Mbps SFP port, one DIP switch, one system LED and other LEDs on the front panel, and one AC power connector and one grounding stud on the rear panel.

Figure 1-1 Appearance of a RG-ES110GS-P-L Switch



1.2.1 Front Panel

Figure 1-2 Front Panel of a RG-ES110GS-P-L Switch

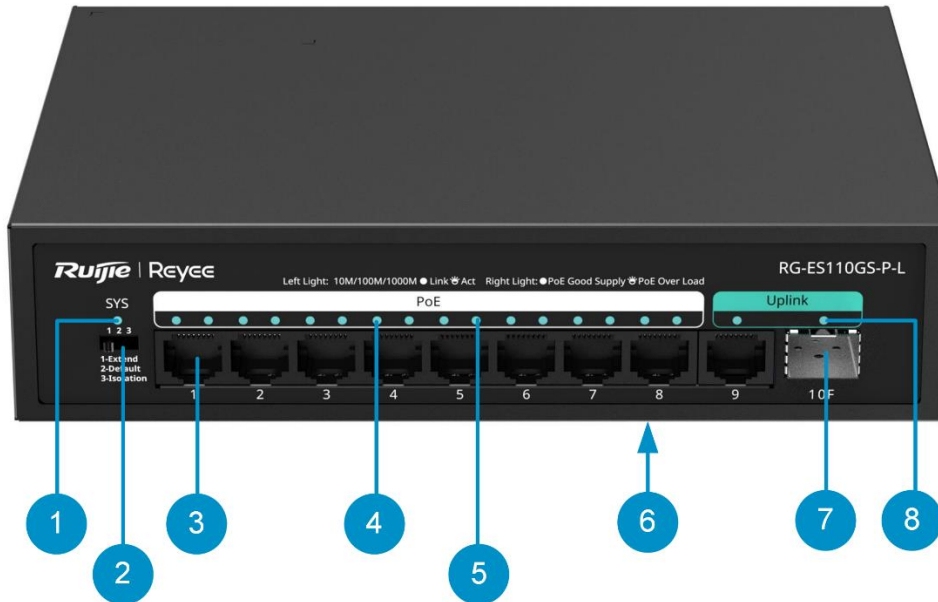

Figure 1-3 Front Panel Components

No.	Component	Description
1	System LED	<ul style="list-style-type: none"> ● Off: The device is not powered on. ● Solid on: The device is powered on.

No.	Component	Description
2	DIP switch	<p>The DIP switch is used to adjust the switch's working mode.</p> <ul style="list-style-type: none"> ● Default mode: All ports can communicate with each other. ● Extend mode: The rate of ports 1 to 8 is reduced to 10 Mbps. Typically, the transmission distance is 200 m (656.17 ft), which is up to 250 m (820.21 ft) in the laboratory environment with Cat5e cables or higher. In addition, factors such as cable quality, powered device performance, and ambient temperature may cause the transmission distance to be less than 250 m (820.21 ft). ● Isolation mode: Ports 1 to 8 cannot communicate with each other, but they can communicate with ports 9 and 10.
3	1000Base-T Ethernet port with auto-negotiation	Nine 1000 Mbps Ethernet ports with auto-negotiation. Ports 1-8 are PoE-capable.
4	10/100/1000Base-T Link/Act LED (Left LED 1–8; LED 9) 10/100/1000Base-T Link/Act LEDs (1–8 left; 9)	<ul style="list-style-type: none"> ● Solid green: A 10/100/1000 Mbps link is established on the port. ● Blinking green: The port is sending and receiving traffic at 10/100/1000 Mbps. ● Off: No link is established on the port.
5	PoE LEDs (1–8 right)	<ul style="list-style-type: none"> ● Solid green: PoE is enabled. ● Blinking green: PoE overload occurs. ● Off: PoE is disabled.
6	Nameplate	On the bottom of the device
7	100/1000M SFP Ethernet Port	The 100/1000M self-adaptive Ethernet SFP port.
8	100/1000Base-T SFP port Link/Act LED (10F)	<ul style="list-style-type: none"> ● Solid green: The port is sending and receiving traffic at 100/1000 Mbps. ● Blinking green: The port is sending and receiving traffic at 100/1000 Mbps. ● Off: No link is established on the port.

1.2.2 Rear Panel

Figure 1-4 Rear Panel of a RG-ES110GS-P-L Switch



Figure 1-5 Rear Panel Components

No.	Component	Description
1	AC power connector	Connect the AC power cord to the AC power connector to supply power to the switch.
2	Grounding stud	Connect to the protective ground through the grounding wire to provide grounding protection.

1.3 Technical Specifications

Table 1-2 Technical Specifications of a RG-ES110GS-P-L Switch

System Specifications	Flash memory	2 MB
	Forwarding rate	14.8 Mpps
	Switching capacity	20 Gbps(bit/s)
Port Specifications	Total number of RJ45 ports	9
	Total number of optical ports	1
	Number of 1GE SFP ports	1

	Number of 10/100/1000BASE-T ports	9
	Long-distance transmission	<p>Yes</p> <p>Notes:</p> <ul style="list-style-type: none"> ● Support a stable transmission distance of up to 200 m (656.17 ft.). In a lab environment, with CAT5e or better Ethernet cables, the transmission distance can reach up to 250 m (820.21 ft.). ● Refer to the note below the specifications table for other restrictions on the long-distance transmission feature.
	DIP switch	<ul style="list-style-type: none"> ● Extend mode: The rate of Ports 1 to 8 is reduced to 10 Mbps, but the maximum transmission distance can be up to 200 meters (Cat5e cables required). Flow control on. ● Default mode: All ports can communicate with each other. Flow control on. ● Isolation mode: Ports 1 to 8 cannot communicate with each other, but they can communicate with ports 9 and 10. Flow control on.
Power Supply and Consumption	PoE Out standard	PoE/PoE+ (IEEE 802.3af/at)
	Number of PoE/PoE+ Out ports	8
	PoE budget per port	30 W
	PoE budget	120 W
	PoE power pins	1–2 (+), 3–6 (-)
	Power input	<p>220 V AC power supply:</p> <ul style="list-style-type: none"> ● Rated input voltage: 110 V AC to 240 V AC, 50 Hz to 60 Hz ● Maximum input voltage: 100 V AC to 264 V AC, 47 Hz to 63 Hz ● Rated input current: 3 A
	Maximum power consumption	<ul style="list-style-type: none"> ● 10 W (with no PoE load) ● 130 W (with PoE full load)
Power supply	Fixed power supply	
Dimensions and Weight	Casing	Metal
	Product dimensions (W x D x H)	190 mm x 150 mm x 43 mm (7.48 in. x 5.91 in. x 1.69 in.)

	Weight	<ul style="list-style-type: none"> ● 0.97 kg (2.14 lbs) (without packaging materials) ● 1.44 kg (3.17 lbs) (with packaging materials)
Environment and Reliability	Fan	Fanless design
	Cooling	Natural cooling
	Mounting options	Wall/Desk
	Hot swapping of cables	Hot swapping supported by the service port and power connector
	MTBF	200,000 hours
	Operating temperature	0°C to 45°C (32°F to 113°F)
	Storage temperature	-40°C to +70°C (-40°F to +158°F)
	Operating humidity	10% RH to 90% RH (non-condensing)
	Storage humidity	5% RH to 95% RH (non-condensing)
	Altitude	-500 m to +5,000 m (-1,640.42 ft. to +16,404.20 ft.)
	ESD protection	<ul style="list-style-type: none"> ● Air discharge: 8 kV ● Contact discharge: 6 kV
	Surge protection	<ul style="list-style-type: none"> ● Service port: ±4 kV for common mode ● Power connector: ±6 kV for common mode and ±4 kV for differential mode
	Ground Leakage Current	≤ 3.5 mA
Certification and Regulatory Compliance	EMC	EN 55032 EN 61000-3-2 EN 61000-3-3 EN 55035 EN 300 386
	Safety compliance	EN 62638-1
	Certification	CE, FCC

 **Warning**

Operation of this equipment in a residential environment could cause radio interference.

i Notes

Before using long-distance transmission, the following requirements must be met.

1. A CAT5e or better Ethernet cable must be used, with an impedance of less than 25 ohms over a 100-meter (328.08-foot) length.
 2. The connected device also supports long-distance transmission.
 3. The supply voltage should be 54 V.
 4. After long-distance transmission is enabled on a port with PoE Out supported, its rate will decrease to 10 Mbps. In addition, the cable material, powered device performance, ambient temperature, and other factors will affect the actual transmission distance.
-

1.4 Cooling

The RG-ES110GS-P-L switch adopt natural cooling. A minimum clearance of 100 mm (3.94 in.) must be maintained around the device to ensure heat dissipation. Dust the device every three months to prevent vents from getting blocked.

2 Preparing for Installation

2.1 Safety Precautions

Note

- To avoid bodily injury and device damage, please carefully read the safety precautions before you install the device.
 - The following safety precautions may not cover all possible dangers.
-

2.1.1 General Safety Precautions

- Do not place the device in a wet area, and keep it away from liquid.
- Keep the chassis clean and dust-free.
- Keep the device away from heat sources.
- Do not place the device, tools and accessories in walking areas.
- Do not wear loose clothes, ornaments or any other things that may be hooked by the chassis during the installation and maintenance.

2.1.2 Handling Safety

- Avoid handling the device frequently after the device is installed.
- Turn off all power supplies and unplug all power cords and cables before the installation or the dismantling.

2.1.3 Electrical Safety

Warning

- Any nonstandard and inaccurate electrical operation can lead to accidents such as fires or electric shocks, causing severe, or even fatal damage to the human body and the device.
 - Direct or indirect touch through a wet object on high-voltage and mains supply can bring a fatal danger.
-

- Observe local regulations and specifications when performing electrical operations. Only qualified personnel should handle these tasks.
- Carefully check the work area for potential hazards, including ungrounded power system, insufficient grounding, and damp or wet ground.
- Locate the emergency power supply switch in the room before installation. In the case of an accident, cut off the power supply immediately.
- Carefully inspect the device and the environment before powering on or off the device.
- Select the right leakage protector (also called “leakage current switch” or “leakage current breaker”) for the power supply system. This device automatically disconnects the power supply in the event of leakage and the risk of electric shock. A leakage protector should meet the following requirements:
 - The rated leakage action current of each leakage protector is greater than twice of the theoretical

maximum leakage current of all the power supplies in the system. For example, if a system is equipped with 16 identical power supplies, and the leakage current of each power supply is equal to or less than 3.5 mA, then the leakage current of the system totals 56 mA. A leakage protector with a rated leakage action current of 30 mA supports no more than four power supplies (that is, action current of the leakage protector/2/Maximum leakage current of each power supply = $30/2/3.5 \approx 4.28$). In this case, 16 power supplies in the system require at least four leakage protectors with a rated action current of 30 mA, with each leakage protector supporting four power supplies. Although the number of power supplies in a system differs in models, the rated leakage action current of each leakage protector divided by two must be greater than the sum of the maximum leakage current of all the power supplies.

- The rated leakage non-action current of a leakage protector should be 50% of the leakage action current. For example, if a leakage protector has a rated leakage action current of 30 mA, the rated leakage non-action current should be 15 mA. The leakage protector will not activate unless the leakage current exceeds 15 mA.

⚠ Caution

- To ensure personal safety, each leakage protector in the system must have a rated leakage action current equal to or below 30 mA, which is the recognized safety threshold for human body current. If the total leakage current of the system exceeds twice the 30 mA limit, the system must be equipped with two or more leakage protectors to maintain safety.
 - For the leakage current value, see [1.3 Technical Specifications](#).
-

2.1.4 ESD Safety

- Properly ground both the device and the floor.
- Keep the indoor installation environment clean and free of dust.
- Maintain appropriate humidity conditions.
- Before installing any pluggable module, wear an ESD wrist strap and make sure that it is well grounded.

2.1.5 Laser Safety

A device with an optical port usually supports multiple types of optical transceivers, all of which are Class I laser products. Pay attention to the following during the use of optical transceivers:

- When an optical transceiver is in operation, ensure that its port is connected to an optical fiber or covered by a dust cap to keep out dust and prevent it from burning your eyes.
- When an optical transceiver is in operation, do not look into its port after removing the optical fiber. Doing so may result in eye injury.

Figure 2-1 Laser Product Warning



Warning

Do not approach or look directly into any optical port under any circumstances. This may cause permanent damage to your eyes.

2.2 Installation Environment Requirements

To ensure the normal operation and prolonged service life of the device, it is essential to install it indoors in a location that meets the following requirements.

2.2.1 Bearing Requirements

Assess the combined weight of the switch and its accessories, such as power supply modules, and verify that the installation site's ground meets the necessary specifications to ensure safe and proper operation.

2.2.2 Ventilation Requirements

Maintain adequate clearance around the device for air circulation and heat dissipation. After connecting various cables, bundle them or place them in cable management brackets to prevent them from blocking air vents.

2.2.3 Space Requirements

Do not install the device directly against a wall. Instead, maintain a minimum clearance of 0.4 m (15.75 in.) around the device for heat dissipation and device maintenance.

2.2.4 Temperature and Humidity Requirements

For optimal device performance and extended service life, it is essential to maintain suitable temperature and humidity conditions in the equipment room. Prolonged exposure to excessively high or low temperature and humidity can potentially cause damage to the device.

- When exposed to high relative humidity, insulating materials may exhibit poor insulation capabilities, increasing the risk of electrical leakage. Furthermore, high humidity can cause mechanical changes in materials and corrosion of metallic components.
- When exposed to low relative humidity, the insulating strip may dry out and shrink, increasing the risk of static electricity generation. This static electricity can pose a danger to the circuits inside the device.
- In a dry environment, static electricity is prone to occur and damage the internal circuits of the device.
- High temperature environments can be detrimental to the device, leading to reduced performance and a shorter service life. Prolonged exposure to elevated temperatures can expedite the device's aging process.

Note

The ambient temperature and humidity of the switch are measured 1.5 m (59.06 in.) above the floor and 0.4 m (15.75 in.) before the switch rack when there is no protective plate in front or at the back of the rack.

2.2.5 Cleanliness Requirements

Dust poses a major threat to the running of the device. The buildup of dust on the device can result in static electricity, causing poor contact between the metallic joints. Dust buildup is more likely to occur in environments

with low relative humidity, which not only impacts the service life of the device but also increases the likelihood of communication failure. The following table shows the specifications for dust concentration and particle size in the equipment room.

Table 2-1 Requirements for Dust

Particle Size	Unit	Concentration
≥ 0.5 μm	Particles/m ³	≤ 3.5×10 ⁶
≥ 5 μm	Particles/m ³	≤ 3.5×10 ⁴

Apart from dust, the salt, acid and sulfide in the air in the equipment room must also meet strict requirements. These harmful substances will accelerate metal corrosion and component aging. Therefore, the equipment room should be properly protected against the intrusion of harmful gases, such as sulfur dioxide, hydrogen sulfide, nitrogen dioxide, and chlorine gas. The following table lists the limits for harmful gases.

Table 2-2 Requirements for Gases

Gas	Average (mg/m ³)	Maximum (mg/m ³)
Sulfur dioxide (SO ₂)	0.3	1.0
Hydrogen sulfide (H ₂ S)	0.1	0.5
Nitrogen dioxide (NO ₂)	0.5	1.0
Chlorine gas (Cl ₂)	0.1	0.3

Note

"Average" indicates the typical level of exposure over a one-week period, while "Maximum" refers to the highest allowable exposure level within a week, with this level being sustainable for no more than 30 minutes per day.

2.2.6 Grounding Requirements

A proper grounding system is crucial for ensuring stable and reliable operation of the device, as well as preventing lightning strikes and interference. To ensure proper grounding, carefully check the grounding conditions at the installation site according to the grounding specifications, and complete grounding properly based on the actual situation.

- Safety Grounding

Ensure that the cabinet and power distribution device are securely grounded if the device uses the AC power supply. Failure to do so may result in an increased risk of electric shock, particularly when the insulation resistance between the power supply inside the device and the chassis decreases.

⚠ Caution

- Please adopt grounding protection connections in buildings so that the device can be connected to the protective grounding system.
 - Verify that the AC socket is reliably connected to the protective grounding system of the building. If not, a protective grounding wire should be used to connect the protective grounding lug of the AC socket to the protective grounding system of the building.
 - The cross-sectional area of the protective grounding wire should be at least 0.75 mm² (18 AWG).
-

- **Lightning Grounding**

The lightning protection system of facilities is standalone, and is composed of a lightning rod, a lower conductor, and a connector connected to the grounding system. The grounding system is usually used for power reference grounding and safety grounding of the cabinet. Lightning grounding is required only for facilities and is not required for the device

- **EMC Grounding**

Grounding required for electromagnetic compatibility includes shielded grounding, filter grounding, noise and interference suppression, and level reference, which contribute to the overall grounding requirements. The grounding resistance should be smaller than 1 ohm, and the grounding terminals of the cabinet should be grounded before the running of the device.

2.2.7 Anti-interference Requirements

- Take interference prevention measures for the power supply system.
- Keep the device away from the grounding equipment or lightning and grounding equipment of the power device as much as possible.
- Keep the device far away from high-frequency current devices such as high-power radio transmitting stations and radar launchers.
- Take electromagnetic shielding measures when necessary.

2.2.8 Lightning Protection Requirements

Although the device provides a certain level of protection against lightning strikes, it remains vulnerable to exceptionally strong strikes. The following lightning protection measures should be taken:

- Ensure that the grounding cable of the cabinet is in good contact with the ground.
- Ensure that the neutral point of the AC power socket is in good contact with the ground.
- Install a power lightning arrester in front of the power input end to enhance the lightning prevention for the power supply.

2.2.9 Installation Site Requirements

Regardless of whether the device is installed on a wall or workbench, the following conditions must be met:

- Maintain a proper clearance around the air vents for heat dissipation.
- Place the device on a clean workbench. In hot areas, air-conditioning is recommended.
- The workbench has proper ventilation and heat dissipation.

- The workbench is sturdy enough to support the weight of the device and its accessories.
- The workbench is properly grounded.

2.3 Tools

Table 2-3 Tools

Common Tools	Phillips screwdriver, power cords, Ethernet cables, fastening bolts, diagonal pliers, and cable ties
Special Tools	ESD gloves, wire strippers, crimpers, RJ45 connector crimping pliers, and wire cutter
Meters	Multimeter
Relevant Devices	PC, display, keyboard

 **Note**

The RG-ES110GS-P-L switch is not delivered with a tool kit. The tool kit is customer-supplied.

3 Installing the Switch

⚠ Caution

Before installing the switch, carefully read Chapter 2 and make sure that all the requirements in Chapter 2 are met.

3.1 Before You Begin

- The installation site provides sufficient space for heat dissipation.
- The installation site meets the temperature and humidity requirements of the device.
- The power supply and required current are available in the installation site.
- The Ethernet cables have been deployed in the installation site.
- The selected power supply modules meet the system power requirements.
- The position of the indoor emergency power switch is located before installation.

3.2 Precautions

To ensure the normal operation and prolonged service life of the device, observe the following precautions:

- Do not power on the device during installation.
- Install the device in a well-ventilated position.
- Do not expose the device to high temperatures.
- Keep the device away from high-voltage cables.
- Install the device indoors.
- Do not expose the device to a thunderstorm or strong electric field.
- Keep the device clean and dust-free.
- Cut off the power supply before cleaning the device.
- Do not wipe the device with a damp cloth.
- Do not wash the device with liquid.
- Do not open the enclosure when the device is working.
- Fasten the device tightly.

3.3 Mounting the Switch

3.3.1 Mounting the Switch on a Wall

i Note

The RG-ES110GS-P-L switch can be mounted on a wall (You need to prepare two KA 3 x 25 mm screws and two expansion anchors by yourself).

The installation steps are as follows:

- (1) Take out two expansion anchors and two screws from the package.
- (2) Drill two holes on the wall at the same height, with a spacing of 120 mm (4.72 in). Insert one expansion anchor into each hole, and drive one screw into each expansion anchor.
- (3) Align the two holes on the chassis with the screws, and hang the switch securely on the screws.

Figure 3-1 Mounting the Switch on a Wall

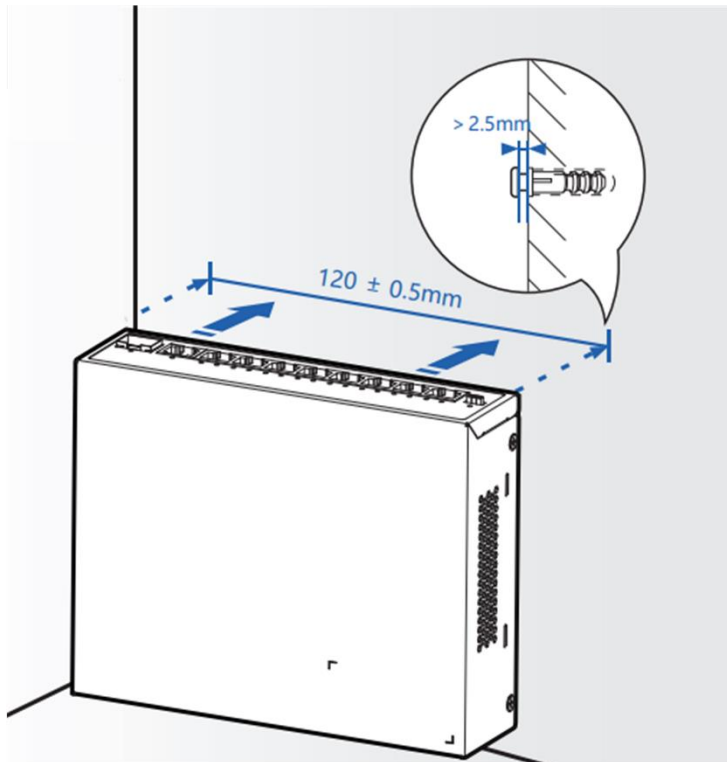

⚠ Caution

When mounting the switch on a wall, ensure it is installed on a non-flammable surface such as concrete.

3.3.2 Mounting the Switch on a Workbench

If it is impossible to mount the switch on a wall, an alternative approach is to place it on a clean workbench. Do not relocate the workbench once the device has been mounted and is in operation to ensure stability and safety.

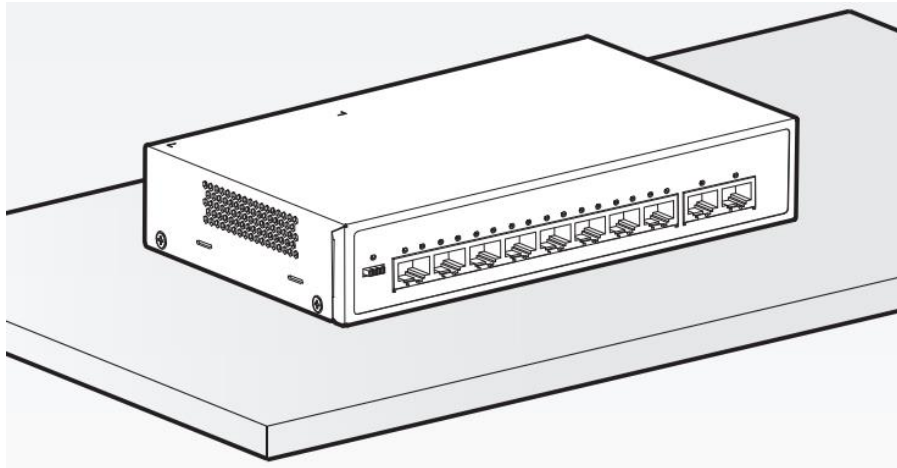
Figure 3-2 Mounting the Switch on a Workbench

3.4 Grounding the Switch

Connect the grounding wire to the grounding stud on the rear panel of the switch.

Note

The grounding wire is not delivered with the switch, and needs to be purchased separately.

3.4.1 Connecting the Power Cord

Warning

Use the power cord delivered with the switch to prevent any potential accidents.

After the switch is installed on a wall or on a workbench, connect the switch to the external interfaces with Ethernet cables. The steps are as follows:

- (1) Connect one end of the supplied power cord to the power connector on the switch.
- (2) Turn off the mains power supply and connect the other end of the power cord to the power socket.
- (3) Use an Ethernet cable with the RJ45 connector to connect the device to the network.

3.5 Checking after Installation

- Verify that the grounding wire is properly connected.
- Verify that the cables and the power cord are properly connected.
- Verify that cables are routed indoors. If not, verify that the power supply and ports are protected from lightning strikes.
- Verify that a minimum clearance of 100 mm (3.94 in.) is maintained around the device for heat dissipation.

4 Debugging

4.1 Powering on the Switch

4.1.1 Checklist Before Power-On

- The switch is connected to earth ground.
- The power cord is properly connected.
- The power voltage meets the requirement.

4.1.2 Checklist After Power-on

After the device is powered on, check the following items:

- LEDs of the switch are in the normal state.
- The main program is loaded properly.
- Service ports can forward data properly.

4.2 Adding Unmanaged Device to Topology

⚠ Caution

There must be devices that can be managed in the network, including Reyee EG or ES2/NBS switches.

Scenarios:

- Add a new unmanaged switch: Select its uplink device, and scan the QR-code on the switch or manually add it to the topology.
- If the unmanaged switch is already added to the topology and displayed as a virtual device: Select the virtual device, and scan its QR-code or manually enter its information to the topology.

4.2.1 Scanning QR-code of Unmanaged Device

(1) Tap **Topology** to open the topology page.

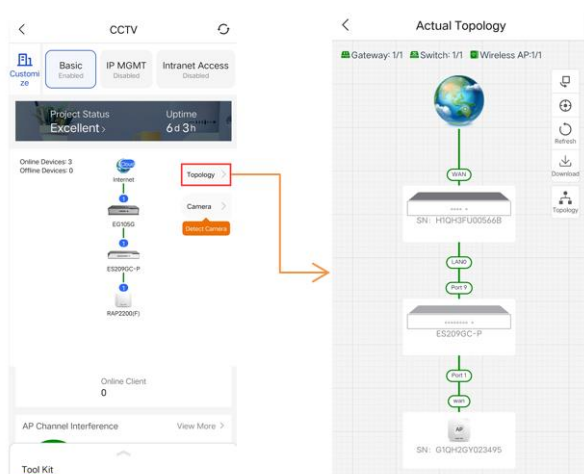

- (2) Tap the **Topology** button, and select the existing managed device. To add an unmanaged downlink switch by scanning its QR-code, select **Scan to Add**.

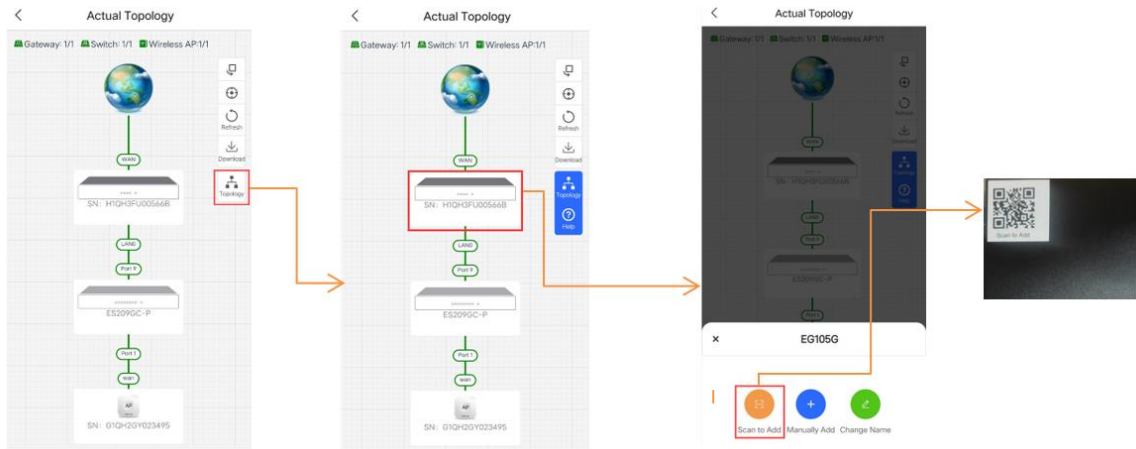

- (3) After the device is detected, select its uplink port. And the device is added successfully.

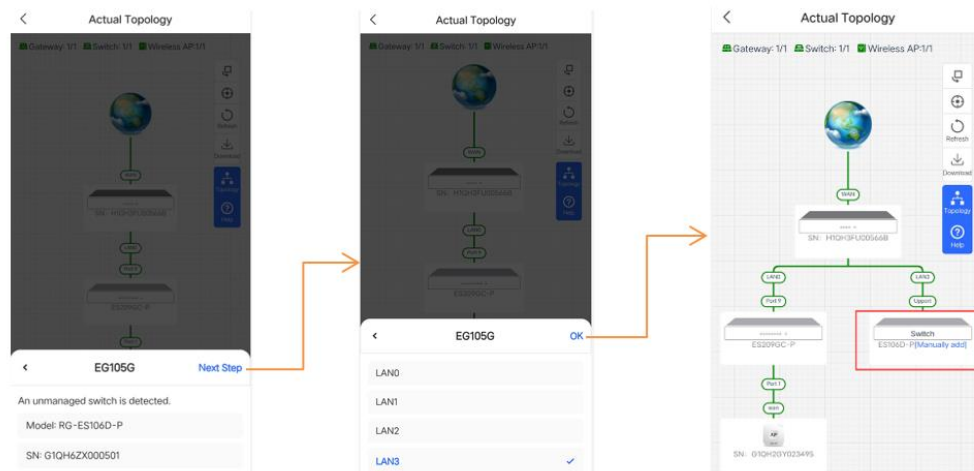

4.2.2 Adding Unmanaged Device Manually

- (1) Tap **Topology** to enter the topology page.

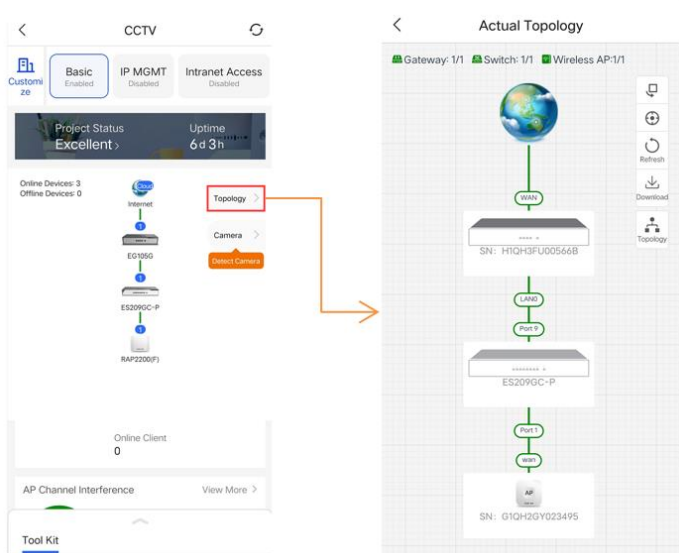

(2) Tap the **Topology** button, and select the existing managed device. To add an unmanaged downlink switch manually, select **Manually Add**.

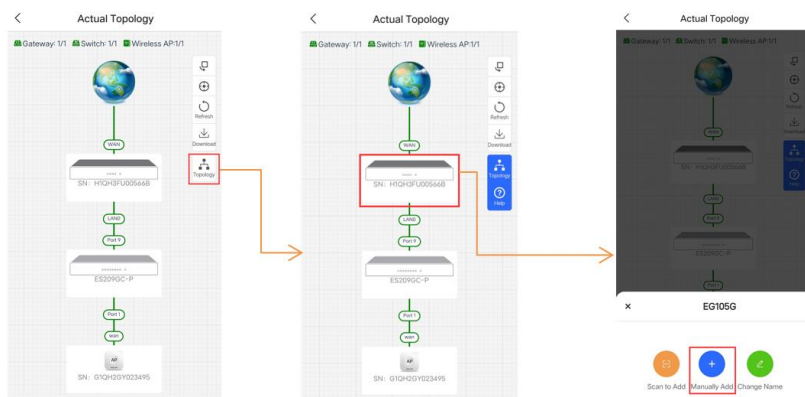

(3) Select the device model and its uplink port, and the device is added successfully.

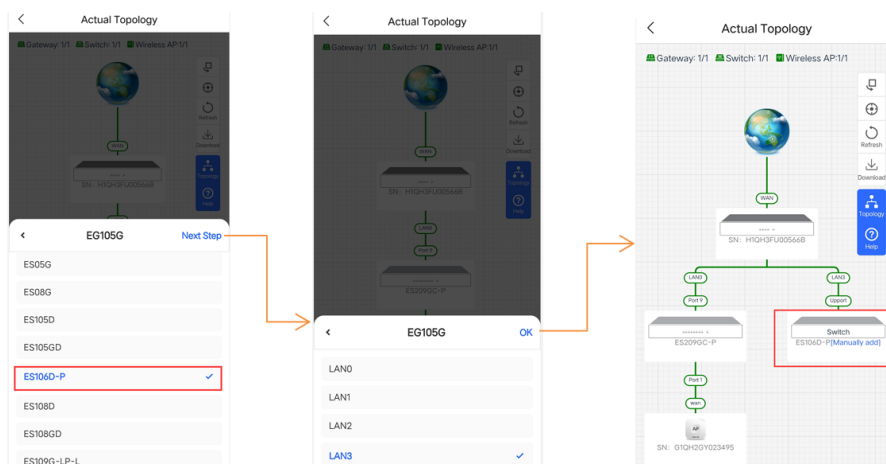

5 Appendix

5.1 Connectors and Media

- **1000BASE-T/100BASE-TX/10BASE-T Ports**

A 1000BASE-T/100BASE-TX/10BASE-T port is a 10/100/1000 Mbps Ethernet port that supports auto MDI/MDIX. Compliant with the IEEE 802.3ab standard, a 1000BASE-T port requires Category 5 100-ohm UTP or Category 5e UTP/STP (STP is recommended) cables with a maximum distance of 100 meters (328 ft.).

The 1000BASE-T port uses four pairs of wires for data transmission, as shown in Figure 5-1.

Figure 5-1 1000BASE-T Connection

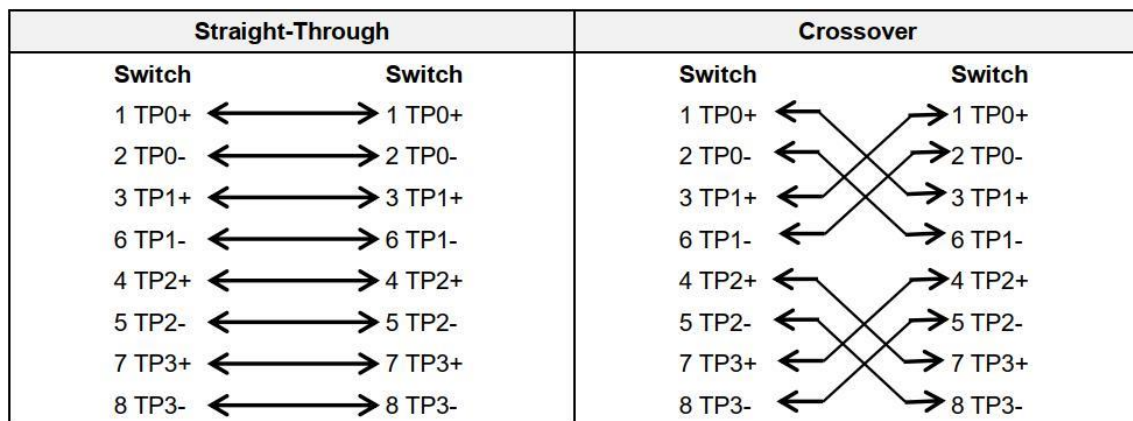

In addition to the above cables, a 10BASE-T port uses Category 3, 4, 5 100-ohm UTP/STP cables while a 100BASE-T port uses Category 5 100-ohm UTP/STP cables. Both support a maximum length of 100 meters (328 ft.). Figure 5-2 shows 100BASE-TX/10BASE-T pin assignments.

Figure 5-2 100BASE-TX/10BASE-T Pin Assignments

Pin	Socket	Plug
1	Input Receive Data+	Output Transmit Data+
2	Input Receive Data-	Output Transmit Data-
3	Output Transmit Data+	Input Receive Data+
6	Output Transmit Data-	Input Receive Data-
4,5,7,8	Not used	Not used

Figure 5-3 shows the wiring of straight-through and crossover cables for 100BASE-TX/10BASE-T ports.

Figure 5-3 100BASE-TX/10BASE-T Connection

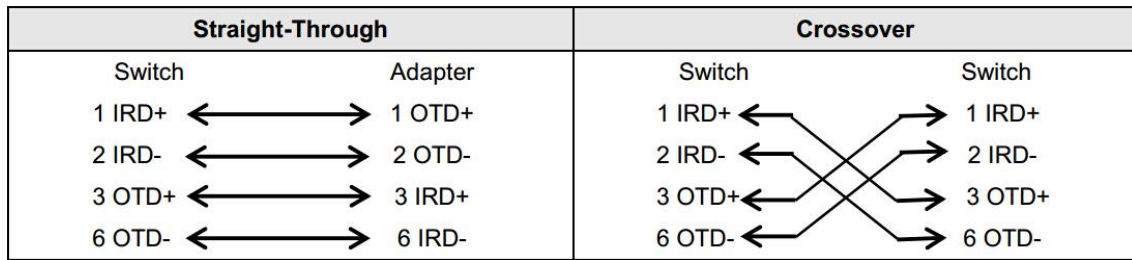

- Optical Cable Connection

Choose single mode or multi-mode fiber (MMFs) according to the module types.

Figure 5-4 Optical Cable Connection

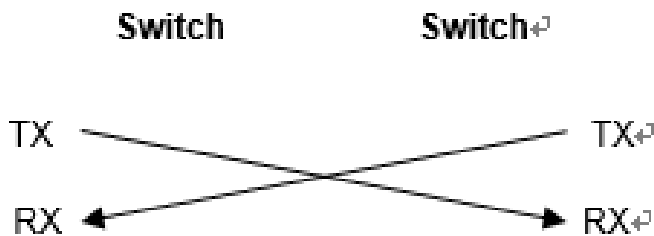

5.2 Mini-GBIC and SFP Modules

We provide appropriate SFP modules (Mini-GBIC modules) according to the port types. You can select the module to suit your specific needs. Besides, the Mini-GBIC-GT modules are also supported. The following models and technical specifications of some SFP modules are listed for your reference. For details about the technical specifications, see *Ruijie Hybrid Cable Installation and Reference Guide*.

Table 5-1 Models and Specifications of 1000M Mini-GBIC (SFP) Optical Modules

Model	Wavelength (nm)	Cable type	DDM (Yes/No)	Intensity of Transmitted Light (dBm)		Intensity of Received Light (dBm)	
				Min	Max	Min	Max
MINI-GBIC-SX-MM850	850	MMF	No	-9.5	-3	-17	0
MINI-GBIC-LX-SM1310	1310	SMF	No	-9.5	-3	-20	-3
GE-eSFP-SX-MM850	850	MMF	Yes	-9.5	-3	-17	0
GE-eSFP-LX-SM1310	1310	SMF	Yes	-9.5	-3	-20	-3
GE-SFP-LX-SM1310	1310	SMF	No	-9.5	-3	-20	-3

Model	Wavelength (nm)	Cable type	DDM (Yes/No)	Intensity of Transmitted Light (dBm)		Intensity of Received Light (dBm)	
				Min	Max	Min	Max
MINI-GBIC-LH40-SM1310	1310	SMF	Yes	-2	3	-22	-3
GE-SFP-SX-SM1310-BIDI	1310	MMF	No	-10	-5	-17	-3
GE-SFP-SX-SM1550-BIDI	1550	MMF	No	-10	-5	-17	-3
GE-SFP-LX20-SM1310-BIDI	1310TX/1550RX	SMF	Yes	-9	-3	-20	-3
GE-SFP-LX20-SM1550-BIDI	1550TX/1310RX	SMF	Yes	-9	-3	-20	-3
GE-SFP-LH40-SM1310-BIDI	1310TX/1550RX	SMF	Yes	-5	0	-24	-1
GE-SFP-LH40-SM1550-BIDI	1550TX/1310RX	SMF	Yes	-5	0	-24	-1
MINI-GBIC-ZX50-SM1550	1550	SMF	Yes	-5	0	-22	-3
MINI-GBIC-ZX80-SM1550	1550	SMF	Yes	0	4.7	-22	-3
MINI-GBIC-ZX100-SM1550	1550	SMF	Yes	0	5	-30	-9
GE-SFP-SX	850	MMF	No	-9.5	-3	-17	0
GE-SFP-LX	1310	SMF	No	-9.5	-3	-20	-3
SFP-MM850	850	MMF	No	-9.5	-3	-17	0
SFP-SM1310	1310	SMF	No	-9.5	-3	-20	-3

Table 5-2 1000Base-T SFP Copper Module

Standard	1000Base-T SFP Module	DDM (Yes/No)
1000Base-T	Mini-GBIC-GT	No

Table 5-3 SFP Module Cabling Specifications

SFP Model	Connector Type	Cable type	Core Specifications (µm)	Max. Cabling Distance
MINI-GBIC-SX-MM850	L/C	MMF	62.5/125	275 m

SFP Model	Connector Type	Cable type	Core Specifications (µm)	Max. Cabling Distance
			50/125	550 m
MINI-GBIC-LX-SM1310	L/C	SMF	9/125	10 km
GE-eSFP-SX-MM850	L/C	MMF	62.5/125	275 m
			50/125	550 m
GE-eSFP-LX-SM1310	L/C	SMF	9/125	10 km
GE-SFP-LX-SM1310	L/C	SMF	9/125	10 km
MINI-GBIC-LH40-SM1310	L/C	SMF	9/125	40 km
GE-SFP-SX-SM1310-BIDI	L/C	MMF	50/125	500 m
GE-SFP-SX-SM1550-BIDI	L/C	MMF	50/125	500 m
GE-SFP-LX20-SM1310-BIDI	L/C	SMF	9/125	20 km
GE-SFP-LX20-SM1550-BIDI	L/C	SMF	9/125	20 km
GE-SFP-LH40-SM1310-BIDI	L/C	SMF	9/125	40 km
GE-SFP-LH40-SM1550-BIDI	L/C	SMF	9/125	40 km
MINI-GBIC-ZX50-SM1550	L/C	SMF	9/125	50 km
MINI-GBIC-ZX80-SM1550	L/C	SMF	9/125	80 km
MINI-GBIC-ZX100-SM1550	L/C	SMF	9/125	100 km
GE-SFP-SX	L/C	MMF	62.5/125	275 m
			50/125	550 m
GE-SFP-LX	L/C	SMF	9/125	10 km
Mini-GBIC-GT	RJ45 Ethernet cable	Cat 5 (or higher) twisted-pair cable		100 m

 Caution

- For optical modules with a cabling distance of over 40 km (24.85 miles) (including 40 km) (including 24.85 miles), install an optical attenuator to avoid overload on the optical receiver when using short-distance single-mode fibers (SMFs).
- An optical module is a laser transmitter. Do not look directly into the optical module to prevent it from burning your eyes.
- To keep the optical module clean, ensure that the unused ports remain capped.

Table 5-4 Pairing Description of the BIDI Optical Module

Rate/Distance	Pairing Model
1000 Mbps/500 m	GE-SFP-SX-SM1310-BIDI GE-SFP-SX-SM1550-BIDI
GE/20 km	GE-SFP-LX20-SM1310-BIDI GE-SFP-LX20-SM1550-BIDI
GE/40 km	GE-SFP-LH40-SM1310-BIDI GE-SFP-LH40-SM1550-BIDI

⚠ Caution

The BIDI modules must be used in pairs. For example, if you install the GE-SFP-LX20-SM1310-BIDI in the local port, you must install the GE-SFP-LX20-SM1550-BIDI in the peer port.

5.3 Lightning Protection

5.3.1 Installing the AC Power Arrester

The AC power connector must be connected to an external lightning protection power strip to prevent the switch from being struck by lightning when the AC power cord is introduced from the outdoor and directly connected to the power connector of the switch. The lightning protection power strip can be fixed on the cabinet, workbench, or wall in the equipment room using cable ties and screws. AC power enters the lightning protection power strip and then gets to the switch.

Figure 5-5 AC Power Arrester

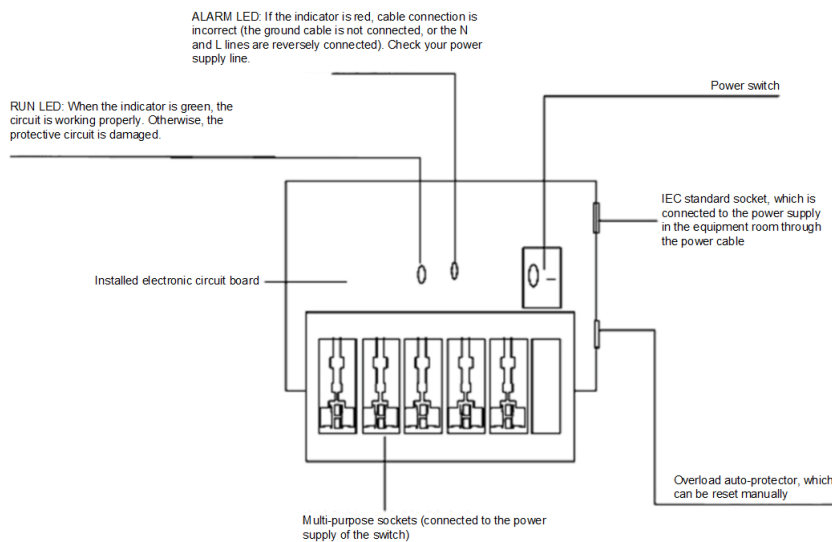

⚠ Caution

The power arrester is not delivered with the switch, and needs to be purchased separately based on actual requirements.

Precautions for installation:

- Ensure that the PE terminal of the power arrester is well-grounded.
- After the switch's AC power connector is connected to the socket of the power arrester (lightning protection power strip), lightning protection function is effective when the RUN LED is Green and the ALARM LED is OFF.
- If the ALARM LED on the power arrester is Red, check whether it is caused by poor grounding connection or by the reversed connection of the Null and Live lines. Use a multimeter to measure the polarity of the power socket for the arrester when the LED is Red. If the N line is on the left and the L line is on the right (facing the socket), the arrester PE terminal is not grounded. If the L line is on the left and the N line is on the right, the polarity of the arrester power cord should be reversed. In this case, open the power arrester and rectify the polarity of the connection. If the LED is still Red, the arrester PE terminal is not grounded.

5.3.2 Installing the Ethernet Port Arrester

Connect an Ethernet port arrester to the switch to prevent any damage caused by lightning before connecting an outdoor network cable to the switch.

Tools: Phillips screwdrivers or flat-head screwdriver, multimeter, and diagonal pliers

Procedure:

- (1) Remove one side of the protective paper of the double-sided adhesive tape and paste the tape to the housing of the Ethernet port arrester. Remove the other side of the protective paper for the double-sided adhesive tape and paste the Ethernet port arrester to the switch housing. The paste position for the Ethernet port arrester should be as close to the grounding stud of the switch as possible.
- (2) Based on the distance between the switch grounding stud and the Ethernet port arrester, cut the grounding wire for the Ethernet port arrester and firmly tighten the grounding wire to the grounding stud of the switch.
- (3) Use a multimeter to check whether the grounding wire for the arrester is in good contact with the grounding stud and the housing of the switch.
- (4) Connect the arrester using an adapter cable (note that the external Ethernet cable is connected to the IN end, while the adapter cable connected to the switch is connected to the OUT end) and observe whether the LED on the board is normal or not.
- (5) Use a nylon cable tie to bundle the power cords.

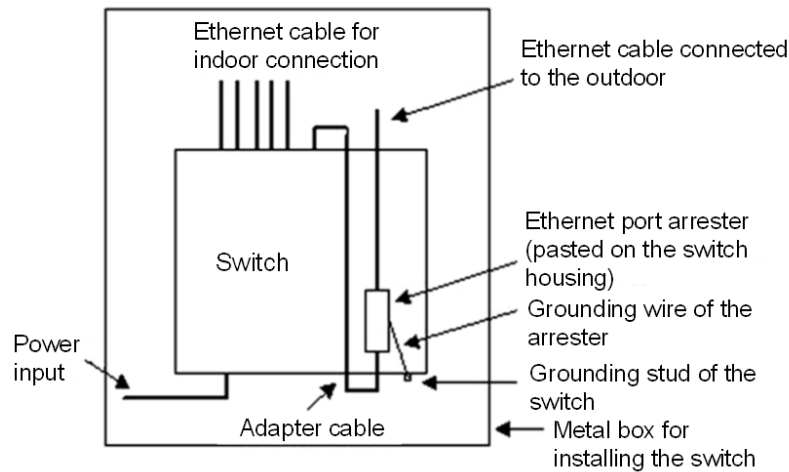
Figure 5-6 Installing the Ethernet Port Arrester

⚠ Caution

- The Ethernet port arrester is only for the 10/100 Mbps Ethernet ports with an RJ-45 connector.
 - The Ethernet port arrester is not delivered with the switch, and needs to be purchased separately based on actual requirements.
-

During the installation, pay attention to the following:

- Reversed direction of the arrester. Connect the external Ethernet cable to the IN end and connect the Ethernet port of the switch to the OUT end.
- Poor grounding of the arrester. The grounding wire of the arrester should be as short as possible to ensure that it is in good contact with the grounding stud of the switch. Use a multimeter to check the contact condition after grounding.
- Insufficient arresters. If there is more than one port on the switch connected to a device, an arrester needs to be installed on each connected port for lightning protection.